



NUMBER: 19-004-09

GROUP: Steering

DATE: August 01, 2009

This bulletin is supplied as technical information only and is not an authorization for repair. No part of this publication may be reproduced, stored in a retrieval system, or transmitted, in any form or by any means, electronic, mechanical, photocopying, or otherwise, without written permission of Chrysler Group LLC.

SUBJECT:

Steering Wheel Returnability

OVERVIEW:

This bulletin involves installing an external power steering cooler and replacing both power steering return lines.

MODELS:

2009 (LX) 300/300C/Charger/SRT

2009 (LC) Challenger/SRT

NOTE: This applies to all 2009 LC and LX vehicles.

SYMPTOM/CONDITION:

After completing a turn the customer may experience a steering wheel that does not return to center on its own.

DIAGNOSIS:

If the above condition is present and determined , perform the Repair Procedure.

PARTS REQUIRED:

Qty.	Part No.	Description
1 (AR)	05137721AA	Cooler, Power Steering (Non-SRT)
1 (AR)	68017995AA	Cooler, Power Steering (SRT Only)
1 (AR)	68067354AB	Hose, Power Steering Return (AWD Only)
1 (AR)	68067353AB	Hose, Power Steering Return (SRT, 2.7L, 3.5L RWD Only)
1 (AR)	04782362AC	Hose, Cooler to Reservoir (Non-SRT)
1 (AR)	04854545AA	Hose, Cooler to Reservoir (SRT Only)
1 (AR)	68066627AB	Hose, Power Steering Return (5.7L RWD Only)
2	05137778AC	Retainer Package, Power Steering Cooler
6	6504737	Rivets, Plastic



Stick with the Specialists™

SPECIAL TOOLS / EQUIPMENT REQUIRED:

C-4207A	Hand Vacuum Pump or equivalent
9688 or 9688A	Power Steering Cap Adaptor

REPAIR PROCEDURE - ENHANCE POWER STEERING COOLER

1. Remove the Front Fascia. Refer to the detailed removal procedures available in DealerCONNECT > TechCONNECT under: Service Info > 23 - Body > Frame and Bumpers> Bumpers > Fascia, Front> Removal.
2. If this vehicle is a:
 - a. LC proceed to [Step #3](#)
 - b. LX proceed to [Step #4](#)
3. Remove the Front Air Dam. Refer to the detailed removal procedures available in DealerCONNECT > TechCONNECT under: Service Info > 23 - Body> 13 - Frame and Bumpers > Bumpers > AIR DAM, Front > Removal.
4. Remove the Belly Pan. Refer to the detailed removal procedures available in DealerCONNECT > TechCONNECT under: Service Info > 23 - Body > Exterior > BELLY PAN > Removal.
5. Remove the left and right cooler baffles ([Fig. 1](#)).

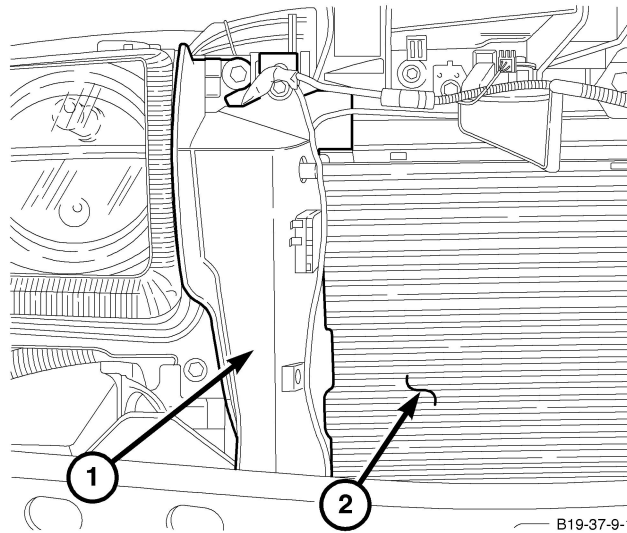
**Fig. 1 BAFFLE (Right Side Shown)**

1 - Right Baffle

2 - Tri-Cooler

NOTE: LX vehicles only**NOTE: In the following step do not remove any air conditioning hoses**

6. Remove (4) Condenser mount screws and tilt the assembly forward. As shown in DealerCONNECT> TechCONNECT under: Service info > 24 - Heating and Air Conditioning/Plumbing/CONDENSER, A/C - Removal> Step 10.

7. Remove the power steering return line hose and cooler clamp from the cooler. As shown in DealerCONNECT> TechCONNECT under: Service info > 24 - Heating and Air Conditioning/Plumbing/CONDENSER, A/C - Removal> Step 5 number 10.
8. Loosen the return line nut at the power steering rack. As shown in DealerCONNECT> TechCONNECT under: Service info > 19 - Steering > Pump > HOSE, Power Steering, Return > Removal > GEAR TO COOLER > Step 7.
9. Is this vehicle a SRT:
 - a. Yes>> Proceed to [Step #11](#).
 - b. No>> Proceed to [Step #10](#) and skip [Step #11](#).
10. For all models except SRT: Using both cooler mounting clips, center the new power steering cooler (p/n 05137721AA) and mount between fins 6 and 7 from the top of the condenser edge ([Fig. 2](#)).

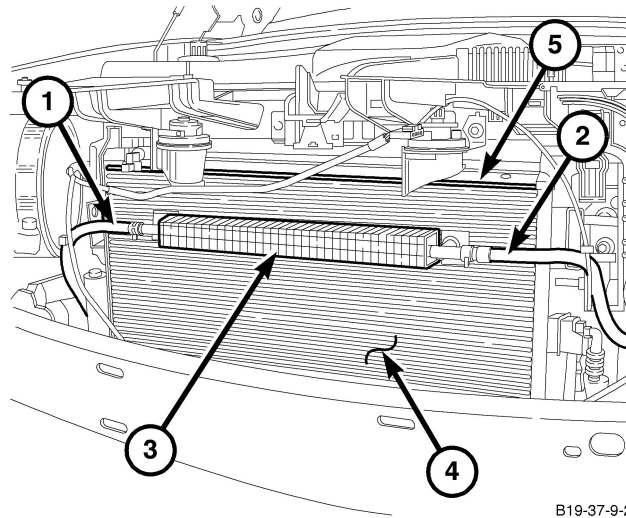

B19-37-9-2

Fig. 2 POWER STEERING COOLER

- 1 - Power Steering Return Hose
- 2 - Power Steering To Reservoir Hose
- 3 - Power Steering Cooler
- 4 - Tri-cooler
- 5 - First Cooler Fin

NOTE: All models except SRT

11. For SRT vehicles only: Using both cooler mounting clips, center the new power steering cooler (68017995AA) and mount between fins 11 and 12 from the top of the condenser edge (Fig. 3).

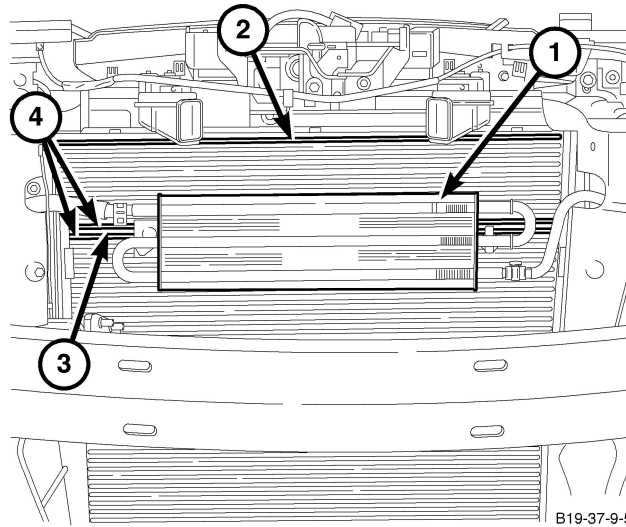

Fig. 3 SRT POWER STEERING COOLER

- 1 - SRT Power Steering Cooler
- 2 - First Cooler Fin
- 3 - Power Steering Cooler Mounting Location
- 4 - Cooler Fins 11 and 12

NOTE: SRT only

12. Reinstall all (4) mounting screws for the cooler.

NOTE: Verify the machine screw is used on the aluminum A/C block on the top right, SRT models do not apply.

13. Remove the Air Box. Refer to the detailed removal procedures available in DealerCONNECT> TechCONNECT under: Service info > 9 - Engine > Air Intake System > Body, Air Cleaner > Removal.
14. Siphon power steering fluid from pump reservoir.

15. Remove the power steering return hose connected to the steering reservoir and using a safety regulated rubber tipped blow gun, extract the remaining power steering fluid in the tri-cooler at 5 psi (Fig. 4).

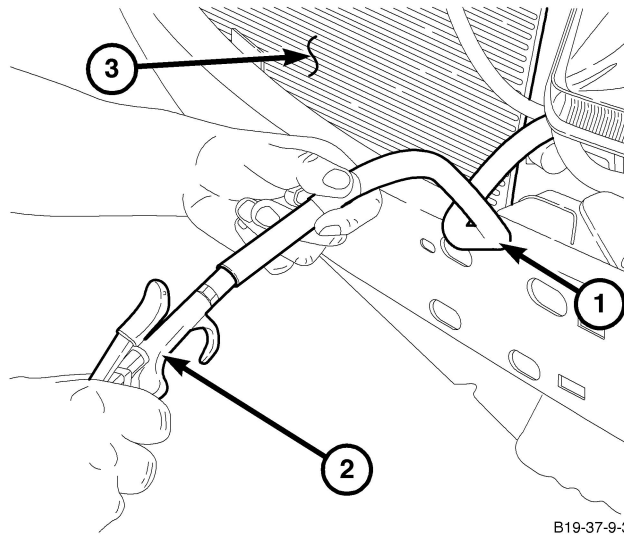

Fig. 4 FLUSH THE FLUID

- 1 - Existing Cooler To Reservoir Hose
- 2 - Safety Regulated Rubber Tipped Blow Gun
- 3 - Tri-cooler

-
16. Remove the return hose from the cooler and discard.
 17. Install new cooler to reservoir hose. Refer to the detailed Installation procedures available in DealerCONNECT > TechCONNECT under: Service Info > 19 - Steering > Pump > HOSE, Power Steering, Return > Installation > COOLER TO RESERVOIR.

NOTE: Keep the black inlet and outlet protective boots from the cooler they will be used in [Step #19](#).

18. Install new power steering gear to cooler hose. Refer to the detailed Installation procedures available in DealerCONNECT > TechCONNECT under: Service Info > 19 - Steering > Pump > HOSE, Power Steering, Return > Installation > GEAR TO COOLER.

19. Install the black protective boots on the old inlet and outlet ports of the power steering cooler and secure them with zip ties as shown in (Fig. 5).

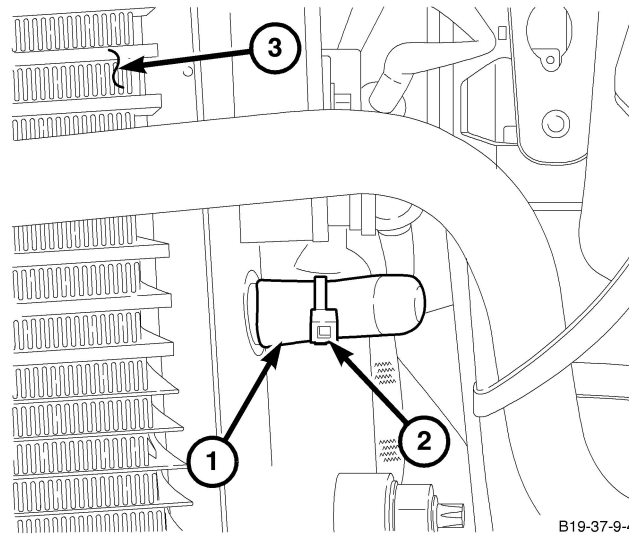

Fig. 5 BOOT COVER

- 1 - Protective Boot
- 2 - Zip-tie
- 3 - Tri-cooler

-
20. Bleed and fill power steering system as required. Refer to the detailed procedures available in DealerCONNECT > TechCONNECT under: Service Info > 19 - Steering > Standard Procedure > Power Steering System Bleeding.
21. For LX vehicles only: Re-install the cooler baffles on the left and right side (Fig. 1).
22. For LC vehicles only: Install the Front Air Dam. Refer to the detailed removal procedures available in DealerCONNECT > TechCONNECT under: Service Info > 23 - Body > 13 - Frame and Bumpers > Bumpers > AIR DAM, Front > Installation.
23. Install the Front Fascia. Refer to the detailed removal procedures available in DealerCONNECT > TechCONNECT under: Service Info > 23 - Body > Frames and Bumpers > Fascia, Front > Installation.
24. Install the Belly pan. Refer to the detailed installation procedures available in DealerCONNECT > TechCONNECT under: Service Info > 23 - Body > Exterior > BELLY PAN > Installation).

POLICY:

Reimbursable within the provisions of the warranty.

TIME ALLOWANCE:

Labor Operation No:	Description	Amount
19-50-20-90	Cooler, Power Steering, Install (LC Models only) (B)	1.1 Hrs
19-50-20-91	Cooler, Power Steering, Install (LX Vehicles Only) (B)	1.3 Hrs.

FAILURE CODE:

ZZ	Service Action
----	----------------